



---

**SOLID FUEL  
RANGE COOKER  
WITH HOT WATER HEATER**

**TYPE 9112-HEU**

---

**OPERATION & MAINTENANCE  
MANUAL  
INSTALLATION MANUAL**

## Declaration

KVS EKODIVIZE, a. s. declares that the hygienic character of the baking accessories intended for contact with foodstuff under all normal conditions, or by the stated use of the manufacturer, comply with the requirements of Law No. 258/2000 Coll., the Ministry of Health Decree No. 38/2001 Coll., and Regulation No. 207/2006 Coll. of the Czech Republic.

KVS EKODIVIZE, a. s.  
Chairman of the Board of Directors

# OPERATION & MAINTENANCE MANUAL

## Dear customer,

Thank you for purchasing of the appliance KVS MORAVIA - solid fuel range cooker with heat exchange unit for connection to central heating hot water system. We trust that our product serves you well. Some important principles should be observed during its operation. Therefore, in your interest, carefully study this manual and operate the product according to the given instructions. The 9112 appliance has a manufacturer issued declaration of conformity according to Section 12, Article 3, of Law No. 22/1997 of the Czech Republic.

## Important Information, Binding Instructions and Recommendations

- No flammable liquids should be used when lighting the fire, nor should they be used to increase the nominal output of the appliance.
- The appliance should not be used for waste incineration; only recommended fuels may be used.
- During operation, the ash tray door should be closed, and the fire door should only be opened for lighting the fire or raking the grate in order to prevent flue gas bleeding.
- **The cooker cannot be used unless it is connected to a functioning water system even during the summer months, otherwise the heat exchanger will be overheated and thus suffer permanent damage.**
- Ash should be put into non-flammable ash bins with covers! Be very careful during the removal of hot ash.
- Pay attention to fire safety!
- It is forbidden to use the appliance if it is damaged (unfit for its function)!
- Any contravention of the operating conditions may cause damage to some parts of the appliance. It is recommended not to overload the appliance in any way. If the temperature in the oven exceeds 300°C the thermometer function could be damaged.
- **Possible noisy impacts (popping) of the metal plates or chipping of the fired clay lining inside the appliance are not subject to repair or a claim procedure. The cause of these impacts is the internal stress of the metal plates, which will fade after a certain time (it depends on the firing frequency). These occurrences endanger neither the safety, nor the function of the appliance.**
- Any repair of the appliance, except cleaning and fired claying must only be made by an authorised worker.
- Local regulations, including those regulations related to national and European standards, shall be observed during the installation of the appliance.
- It is recommended that you only use spare parts approved by the manufacturer.
- Unauthorised modifications of the appliance are forbidden.
- The appliance must only be operated by adults, and during operation, the appliance requires intermittent attendance and supervision.
- **The appliance should be installed by an authorised specialist. No claims are accepted in case of incorrect or amateur installation.**

## Technical Specifications TYPE 9112-HEU

The TYPE 9112-HEU appliance has been designed for solid fuel combustion in periodic feed rates and it is intended for cooking and baking in households and/or for heating the space in which it is situated, according to the ČSN EN 12815:2002 Standard as amended A1:2005. The appliance can be connected to a chimney from the back, both sides or from the top by means of a hole in the Hob-Top (Drawing 1). It is available in either left or right versions. The appliance is suitable for short operational periods, so it is not possible to set the permanent-heat process with a shortest interval of fuel supply of 10 hours.

<b>Appliance Characteristics</b>	<b>TYPE 9112-HEU</b>
Nominal Heat Output – NHO (power range)	9 kW
Heat flow: into the space, to the water (to the water range)	5,5 kW 3,5 kW
Efficiency at NHO	75 %
Average temperature of flue-gas at NHO	190 °C
Mass flow rate of flue-gas at NHO	12 g/s
Minimum chimney draught	12 Pa
Height of the worktop (distance from floor to hob top panel)	850 mm
Width of the appliance	924 mm
Depth of the appliance	600 mm
Diameter of the exhaust flue	120 mm
Height to the centre of the exhaust flue	735 ±0,5 mm
Area of the cooking range	0,37 m <sup>2</sup>
Average wood consumption	3 – 4 kg/h
Weight	175 kg
Connection to the hot water system	1"
Heat Exchange Unit water capacity	9 l
Heated space	125 – 150 m <sup>3</sup>
Operational pressure of the heat exchanger	2 bar
<b>Dimensions of the Fire Box</b>	
Width x Height x Depth	190 x 220 x 450 mm
Fire grate, Width x Depth	140 x 300 mm
Stokehole, Width x Height	197 x 200 mm
<b>Dimensions of the Baking Oven</b>	
Width x Height x Depth	302 x 250 x 433 mm
<b>Accessories</b>	
Pan	1 pc.
Baking oven grate	1 pc.
Poker	1 pc.
Glove	1 pc.

## Description TYPE 9112

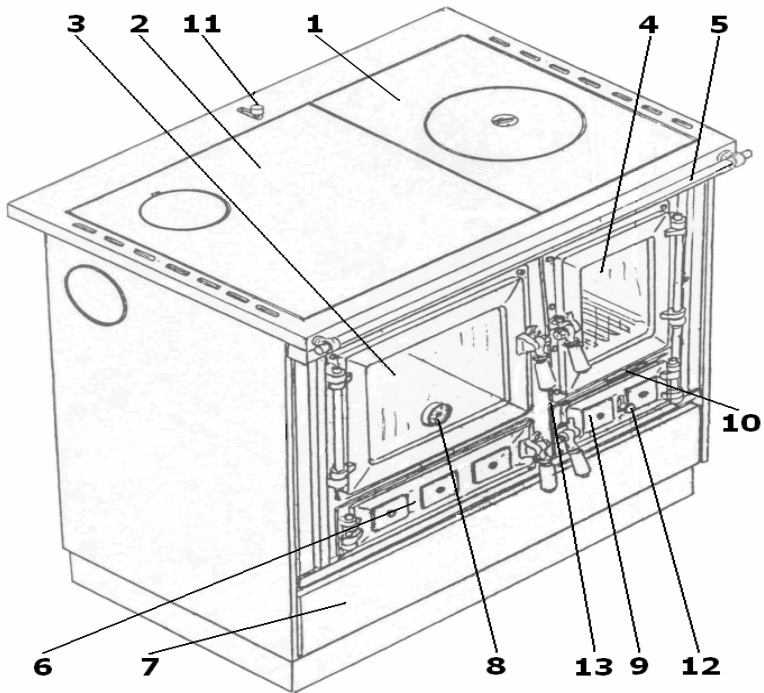

**Drawing 1**

- |                                       |                                    |
|---------------------------------------|------------------------------------|
| 1. Hob Top – Plate I                  | 7. Solid Fuel Storage Drawer       |
| 2. Hob Top – Plate II                 | 8. Thermometer                     |
| 3. Oven Door                          | 9. Ash chamber Door                |
| 4. Combustion chamber (Fire-box) Door | 10. Grate bar                      |
| 5. Hand Rail                          | 11. Smoke Flap Control             |
| 6. Sweeping Door                      | 12. Combustion Air Intake Control  |
|                                       | 13. Secondary combustion air lever |

## Service Instructions

### Fuel

The appliance is designed for combustion of solid fuel:

- recommended fuel is wood (max. diameter 190 mm, max. length 450 mm).
- the appliance also enables burning of other kinds of solid fuel (wood briquettes, waste wood, brown coal briquettes, brown coal blocks 40 mm). However the operating conditions and parameters of the appliance may differ from those with the recommended fuel. Please note that the technical characteristics given above were based on a test wood fuel sample and using other fuel types will alter these characteristics, energy output, fuel consumption, flue draught etc. Make sure that the fuel is dry. It is not recommended to burn high-calorific fuels, which reduce the service life of the appliance.

### Grate, Grating

The purpose of the grate is allowing the burned fuel to fall to the ashtray, which increases the supply of combustion (primary) air to the combustion chamber. It is done by means of the poker with the combustion chamber door open.

After the end of each operation (and cooling down) it is possible to grip the grate lever to move the grate back and forth. To remove the pieces which are too big to fall through, rotate the grate a few times by means of this lever.

### Air Supply Control

Controlling the supply of primary combustion air is enabled by means of the air rose, which is a part of the ashtray door. Turning the rose by means of the rose handle enables precise control of air to the combustion chamber and thus alters the speed of fuel combustion (energy output of the appliance).

The secondary combustion air supply can be controlled by means of a lever on the front part of the appliance (Drawing 1, point 13). Air supply is opened (flap is opened) by movement of the lever towards to the front side of appliance and it is closed (the flap is closed) by movement from the front side. Movements lock on the lever by neck.

During the operation of the appliance the supply of the combustion air must be maintained, the air supply inlet must not become blocked. Mechanical ventilation/ air extraction must not be used in the room where the appliance is placed, unless there is provided sufficient air supply for ventilation. Ventilation levels are provided in your local building regulations. It is advised to check ventilation issues with your local building control office to ensure trouble free operation.

### The Ash Extracting Door (Drawing 1, point 6 – Sweeping door)

When the cooker has been in operation for some time, soot will collect in the cooker parts of the draught system (especially where coal has been used). This will eventually affect the draught and may create problems while lighting the fire. It will also make operation of the cooker less economical, especially when cooking in the oven.

In the course of cleaning take off the hob top plates, then remove the soot first from the sides of the oven walls. Clean all the removed deposits through the ash extracting slot situated under the oven door. This can be done simply by using damp newspaper, for example.

### Appliance hob-top panel (variants)

1) The standards panel consists of two parts (Drawing 2):

Plate I. – a cast iron range hob with a round removable centre plate located directly under the fire box. This plate is meant for fast cooking

Plate II. – a steel hob is located above the oven. This plate maintains a lower temperature and thus can be used for slower cooking, simmering and keeping food warm.

2) The single-piece ground steel finish hob-top panel.

3) The single-piece glass and ceramic panel.

You should always use pots with flat bases.

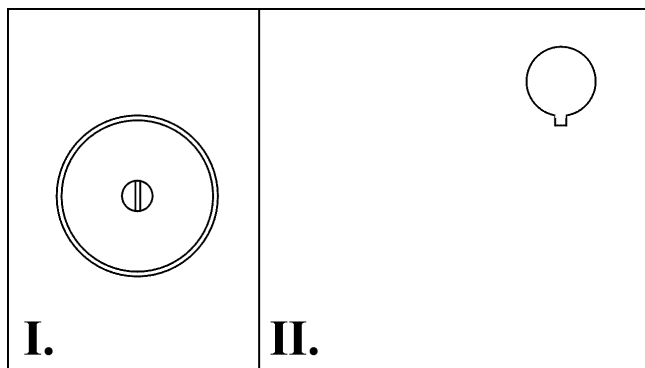

Drawing 2

### Ignition Flap (Drawing 3)

Is placed below the range and controlled by means of the lever located at the rear of the range frame. It has the following operating modes:

Open position – Ignition and intensive cooking throughout the entire range area I.+II.  
(Flap open)

Closed position – Baking in the oven and Cooking on the Plate I.  
(Flap closed)

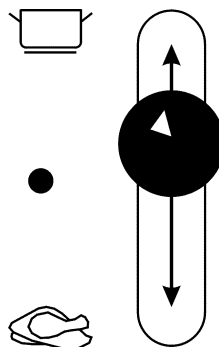

Drawing 3

Following ignition, after the fire has caught, close the ignition flap and operate the appliance with the ignition flap closed. This will influence the flow of flue-gas and increase the efficiency of the appliance.

## Appliance Operation

When you are firing the appliance for the first time, ensure sufficient ventilation of the room, until the protective coatings have completely burned off. Once satisfied that the coatings are no longer present the cooker is safe to use for the purpose of cooking food.

Before ignition open the furnace door and check if the grate is clean. Take twists of paper, lay out tiny chips of dry soft wood on it, then lay larger pieces of dry wood on the chips and then light the paper. Special matches are available to carry out this operation at a distance from the flame.

Before ignition open the ignition flap (Drawing 3). Open the air supply under the grate through the air rose to the maximum and also the secondary air supply.

**The cooker cannot be used without a water pump connected to the domestic central heating system to prevent damage to the heat exchanger caused by overheating. The pump should be already in operation when starting the fire!!!**

After the fuel is ignited close the combustion chamber door and when the fuel burns through, stoke up. After a layer of burning embers is formed you can add more fuel in batches. Make sure not to extinguish the fire by adding excessive amounts of fuel too quickly.

Gradually prolong the intervals of stoking, so that the final interval is once an hour. The average fuel consumption is 3 – 4 kg of fuel per hour. Adding of fuel shall be done manually or by means of a suitable shovel. Full combustion can be visually easily checked: no heavy smoke can be seen rising from the chimney (except the time immediately after stoking up).

If you add half the amount of fuel every thirty minutes and perform grating at the same time, the combustion performance will improve.

The appliance output can be controlled by the supply of air under the grate and by the amount and type of fuel. When operating the appliance at the rated thermal output and burning wood, the primary air supply shall be opened to approx. 20 %, the secondary air supply closed. From time to time clean the grate by means of the poker. If the appliance emits smoke into the room during stoking up, close the air supply. Do not overheat the appliance by too intensive stoking up and grating!

The entire combustion chamber can be filled with fuel. Make sure that the fuel does not fall out of the combustion chamber during stoking up. In case of bad draught or weather conditions use smaller wood logs.

### Recommendations for setting of stabilisation operation:

Lay a wood log of 190 mm diameter and 450 mm length on the bottom burning layer. Close both the primary and secondary air supply. With these settings the appliance should keep burning for up to 3 hours.

### **Cooking on the Appliance Hob Top**

The range above the combustion chamber is designed for fast cooking. With the described set operation, 2 litres of water in a pot with flat bottom of a diameter of 180 cm with a lid should start boiling in 15 minutes.

During cooking watch out for boiling over. If it happens, remove as much of the spillage immediately and when finished cooking clean the remainder using a damp towel, detergent and finally using a dry towel. If the dirt bakes in, it is more difficult to remove later. From time to time (depending on the frequency of operation) wipe the range down with vegetable oil.

In the area above the oven the range has a lower temperature - this part of the range is suitable for slow cooking and for keeping food war. Use pots with a flat bottom for best results.



## Baking and Roasting

If you want to bake in the appliance, the oven has to be sufficiently heated and thermally stabilised. Use smaller dry logs for fast firing of the oven. Set the ignition flap to the “baking” position.

A typical baking temperature is reached in approx. 15 minutes. However, we recommend that you start baking after half an hour to an hour, when the appliance is warmed-through evenly and the temperature in the oven is stable and even.

For roasting of joints of meat we recommend achieving a stabilised temperature indication on the oven door thermometer between 170°C and 200°C. A typical roasting time would be 1 ½ to 2 hours.

For baking pastry and cakes we recommend the temperature indicator on the oven door is stabilised between 140°C and 180°C. The time of baking is typically from 20 to 40 minutes.

To ensure even baking/ roasting we recommend turning the tray around halfway through the cooking process.

If you want to reduce the intensity of baking (e.g. for drying of fruits), use an empty tray as a shield from below or from above.

When taking out the tray with food, you must not lay it on the cooking range hob. The temperature of the cooking range hob is much higher than that of the oven and the food could easily boil over or burn. We also do not recommend laying the tray with food on the open oven door.

The baking accessory of the appliance is designed for short-time contact with food. The short-time contact should not exceed 4 hours for drinks and 48 hours for food of solid or pasty consistence.

## The Heat Exchange Unit

The range cooker with built-in heat exchange unit demands more user attention than a standard cooker or a typical boiler as it requires a more regular supply of solid fuel into the burner, as well as regular poking/stirring of firebox grates. It is not possible to fix a stable temperature level.

We recommend connection of this model to a maximum of two metal radiators, each up to 1200 mm in length and a heating water tank of 60 litres capacity. Before installation each radiator should be fitted with an isolation valve.

Due to the considerably low capacity (9-12 kW) of this model in addition to the variable operating conditions such as fuel type, chimney draught, ambient temperatures etc., **we recommend the following :**

- Only one heating device (one radiator or heating water tank) should be turned on during the kindling process. The remainder of the devices can be introduced later.
- In case of long time baking in the oven only one heating device must be turned on and adding the fuel at 30 minute intervals.
- During the summer setting at least one heating device should be switched on, for example, a heating water tank (**as there should be water in the heat-exchange unit**).

The heat exchange unit incorporated into the range cooker is necessarily of a compact size and has limited water capacity. We recommend that the unit is only connected to a pumped water feed with a thermostat rated at 45°C. If the thermostat exceeds the recommended water temperature, this is likely to cause heat damage.

**Note: For the purpose of taking surplus heat from the heat exchange unit, we recommend to use additional heating device.**

## Cleaning and Maintenance

### Cleaning of the Furnace and Flue Paths

To maintain optimum, problem-free performance of the appliance it is necessary to clean it regularly. Cleaning of the fire box must always be done with the appliance out of operation.

If igniting the combustion chamber after a longer interruption of operation, it is necessary to check that flue paths, flue ducts and chimneys are not blocked and no obstructions are present. Regular maintenance should be carried out once a year by a service engineer.

Remove unburned remnants from the grate by means of the trowel and poker. To drop larger pieces of unburned fuel to the ashtray, pull out the grate lever and turn it to the right. Cleaning of the inner walls of the appliance (draught system) and inner housing of the oven shall be done as follows:

Remove the range hob to get access to the dirty surfaces inside, from which you can sweep the soot easily down to the bottom of the appliance. From there you can sweep them into the ashtray through the sweeping hole. Once clean put the range hob back ensuring that individual parts fit tightly and seal perfectly.

### Outer surfaces cleaning

Clean the appliance after cooling.

- Enamelled surfaces should be cleaned with a damp cloth or sponge, and then polished to dryness. With higher pollution you can use detergents.
- It is important to protect the hob from water to avoid corrosion. Clean them only when they are dry. If you use a damp cloth with detergent when cleaning the hob, the hob should be dried when finished. From time to time we recommend greasing the hob with a thin layer of vegetable fat.
- During oven cleaning, do not use sharp objects to remove food waste. Moisten them before removing with a brush and wiping with a cloth, or alternatively, a suitable cleaning agent for the removal of heavy impurities and accretions may be used.

## Trouble - Shooting

The appliance cannot be lit:	-inspect the flue ways, flue gas duct and chimney -check the Ignition flap, circular air grid, fire place door and ash tray
Overheated appliance	-put out of service, do not stoke, close the air grid, let fire burn out
Fire in the chimney	-do not use water to extinguish the fire -close all of the air intakes, cover the chimney if possible -contact a qualified chimney sweep service -contact the manufacturer or your supplier

## Claims

Do not carry out repairs by yourself if faults occur during the guarantee period. File a claim in the shop where the product was bought or in a guarantee repair shop and support it with a duly completed guarantee card. Guarantee claim requests can be set up only in cases where all guarantee conditions are met.

## Disposal of Packaging

Corrugated cardboard, wrap. paper - can be used to light fire

- recycle

Wooden parts

- can be used as fuel

- recycle

PVC bands, bags, plastic sheets

- recycle if available, or dispose of sensible

Metal bands, nails

- recycle

## Disposal of the Appliance after its Service Life

The appliance contains valuable materials that can be recycled. Your Local Authority or a licensed scrap firm can organise this for you.

### NOTE:

The manufacturer reserves the right to carry out small changes resulting from innovative or technical changes of the product that will have no detrimental affect on the function of the appliance.

## Important notice

### 1. Production standards

KVS MORAVIA solid fuel appliances are produced in accordance ČSN EN12815:2002 Standard with amended A1:2005, which is valid for the Czech Republic and European Union.

### 2. Installation and operation standards

All the above installation and operation instructions for the appliances primarily comply with the Czech regulations, and may not comply fully to individual national regulations at place of installation and use!

The buyer should consult their installer or specialised officials on all of the local installation and operation regulations for this appliance or similar appliances!

# INSTALLATION MANUAL

Based on the design solution and the use to which the appliance will be put, this solid fuel appliance must be installed into an environment which was defined as ordinary environment (for example by standard ČSN 33 2000-3:1995 – Environment standard of the Czech Republic).

Requirements for combustion air supply will be met if the appliance is installed in a room with a minimum volume of 20 m<sup>3</sup>. According to need, the appliance operation or in combination with the contemporary operation of other heat equipment in the room, additional ventilation may be necessary. In cases where dangerous situations may arise, such as the temporary formation of combustible gases and works which may cause a fire to start (potentially explosive), the appliance should be put out of service (by closing the combustion chamber door the fuel will be allowed to burn out on the grate). If combustion, venting and heating air control louvers are used, it is necessary to place them in such a way that clogging cannot occur.

## Appliance connection to the chimney

A flue (exhaust) branch is installed to an outlet on the appliance (rear, sides, and top – through the hob-top). The installation is carried out in such a way that a ring is applied to the internal side of the appliance, which connects with the external flue branch, and they are mutually screwed together moving in the opposite direction.

In case you use a side outlet, it is first necessary to unscrew the side part, from which we dismantle the top cover of the hole, apply the blanking cap to close the rear outlet, replace the side part and screw it closed.

With the use of the top outlet (through the hob-top) it is necessary to remove the blanking cap and to attach the flue branch – without the ring, and use the delivered blank cover to close the rear outlet.

A chimney with a sufficient draught is absolutely essential for correct appliance operation. **We recommend the chimney with height of 5 meters and diameter of 160 mm.** Try to connect the appliance using the shortest route. Flue gas ducting made of sheet-metal tubes consists of several sections and longer than 2,000 mm shall be firmly anchored. The entire set shall be mutually, firmly and tightly connected in the draught direction (individual overlaps must be a minimum of 80 mm). An existing chimney flue shall be provided with an approved liner flue that corresponds to the exhaust flue diameter.

Connection of the appliance to the chimney should comply with the individual national regulations at place of installation and use (for example ČSN 73 4201:2008 Standard of the Czech Republic). The chimney shall be issued with a certificate (revision report) given by a respective authority (chimney sweeping agency). The appliance should be installed in such a way that adequate access can be provided for cleaning of the flue ducting and the chimney. In assembly, it is necessary to observe the principles of fire safety (for example according to the ČSN 06 1008:1998 Standard of the Czech Republic).

## **The cooker can't be connected to a shared chimney (Drawing 4).**

Chimneys and flue ducting to which solid fuel are connected shall be swept 2 times or 3 times a year – seasonal or yearlong operation (for example according to the Czech governments Decree No. 91/2010 Coll.). Routine operation, especially due to damp fuel, soot and tar creates deposits in the chimney. If regular inspection and chimney cleaning are omitted, the probability of a fire in the chimney increases.

## Safety instructions

The minimum safe distance from flammable matters with a combustibility grade of B, C<sub>1</sub>, C<sub>2</sub> is a minimum 750 mm forward of the appliance and 200 mm to the sides and. For flammable matters with C<sub>3</sub> combustibility grade and/ or with an unproven combustibility grade, the distance should be doubled. No flammable objects should be laid on the appliance and should be kept at a safe distance from it. When the appliance is situated on a floor made of a flammable material, it should be set on a fireproof, thermo-insulating plate overlapping its section plan:

- not less than 600 mm at the front (before the stoke hole)
- not less than 300 mm from the lateral side of the stoke hole.

A protective baffle plate is used in cases where, due to space reasons, the prescribed safe distance cannot be kept. The protective baffle plate shall have a constant position between the appliance and the protected material in a distance of 30 ±5 mm from the protected material. The protective baffle plate shall overlap the protected material up to the nearest wall (ceiling) made of a fireproof material, however not less than 300 mm at the upper side and 150 mm at the lateral sides. **We recommend that your installer check this reduced dimension with your local building control department.**

Description of materials type for flammable classification in cookers manuals (in accordance with Czech and EU standard No.73 0823):

Flammable level	Rating	Materials
A.	Non-flammable	asbestos, brick, ceramic wall tile, chamotte, plaster mixture (without organic enclosure).
B.	Uneasy-flammable	building wall panels (for example a gypsum wallboard), VELOX, IGNOS, touchstone felt panels, fibreglass panels).
C <sub>1</sub> .	Flammable with difficulty	beech wood, HORBEX board, wood multi-layer board, WERZALIT, Formica, felt boards.
C <sub>2</sub> .	Moderately flammable	pine tree wood, larch wood, spruce wood, wood chip boards.
C <sub>3</sub> .	Easily flammable	sarking felt, cellulose boards, tar panels, wood-pulp fibre, phellem, polyurethane, polystyrene, polypropylene, polyethylene.

### Warning for places where burns can occur:

- hob-top, hob frame
- combustion chamber door, oven door
- oven inner walls

### Connection to the Central Heating System

- **The appliance should be installed by an authorised specialist. No claims are accepted in case of incorrect or amateur installation.**
- Place the cooker on the plate surface!
- Connect the water intake and discharge from the heat exchanger to the central heating system following the scheme instruction.
- Mount the water pump to the intake water pipe.
- If the radiators are situated on the level of the cooker, it is necessary to use the connection with an open expansion tank in case of some air vaporization from the exchanger.
- If the connection with the expansiomete – is used, it is necessary to mount a safety-valve of 1,8 bar  $\frac{3}{4}$ " and supply a reserve driving source for the pump in case of a failure in electricity supply.
- **The cooker cannot be used without a water pump!!! The pump should be already in operation when starting the fire!!!**
- The cooker cannot be used unless it is connected to a functioning water system even during the summer months, otherwise the heat exchanger will be overheated and thus permanently damaged.

### Flue gas ducting connection to the chimney

(valid for Czech Republic)

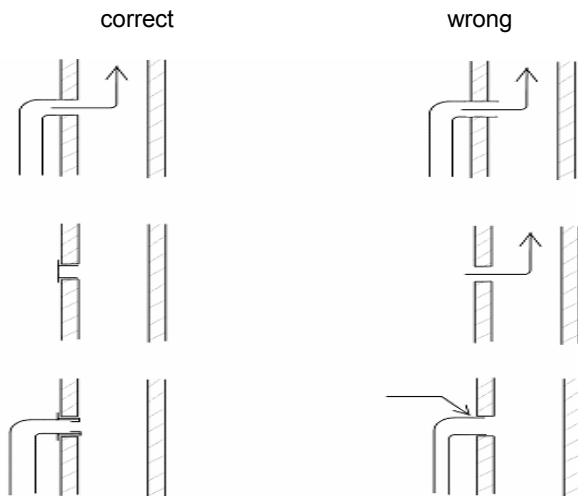

Drawing 4

# Dimensional Sketch of the appliance

## TYPE 9112

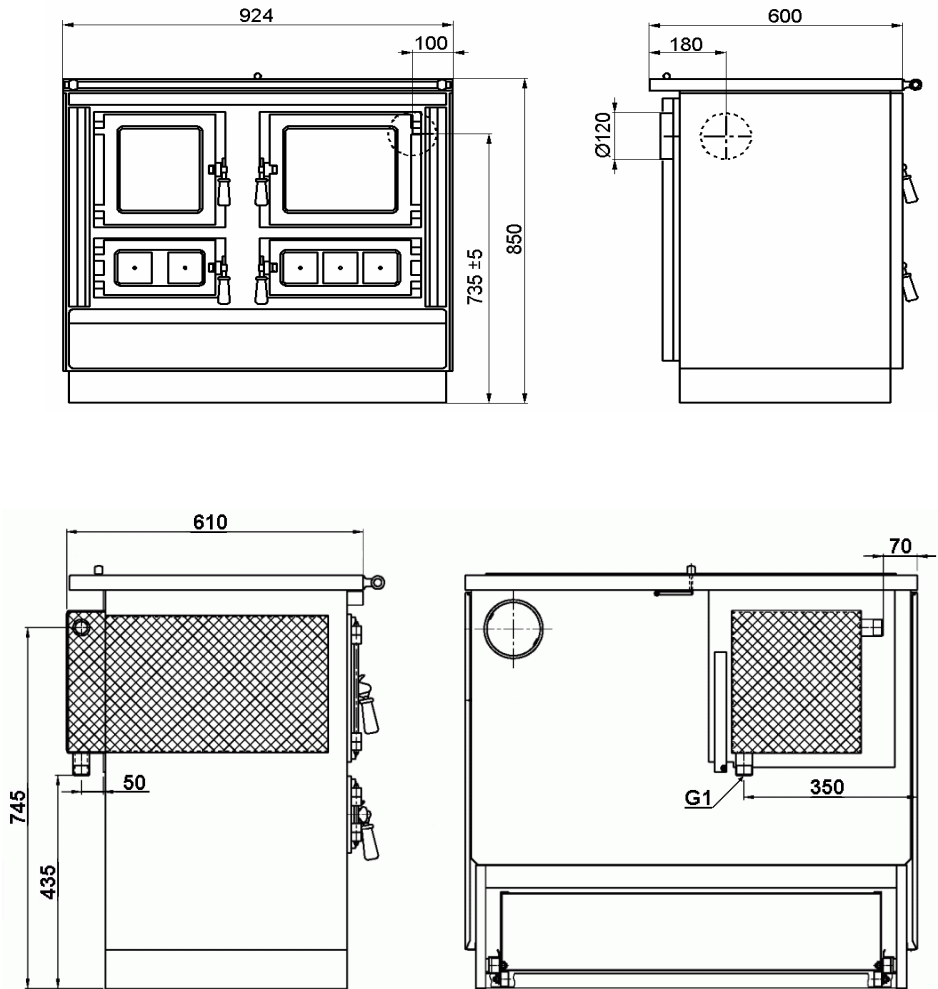

(All of dimensions are in mm)

**Installation schematic of the range cooker with a heat exchange unit within the interior of a domestic dwelling**

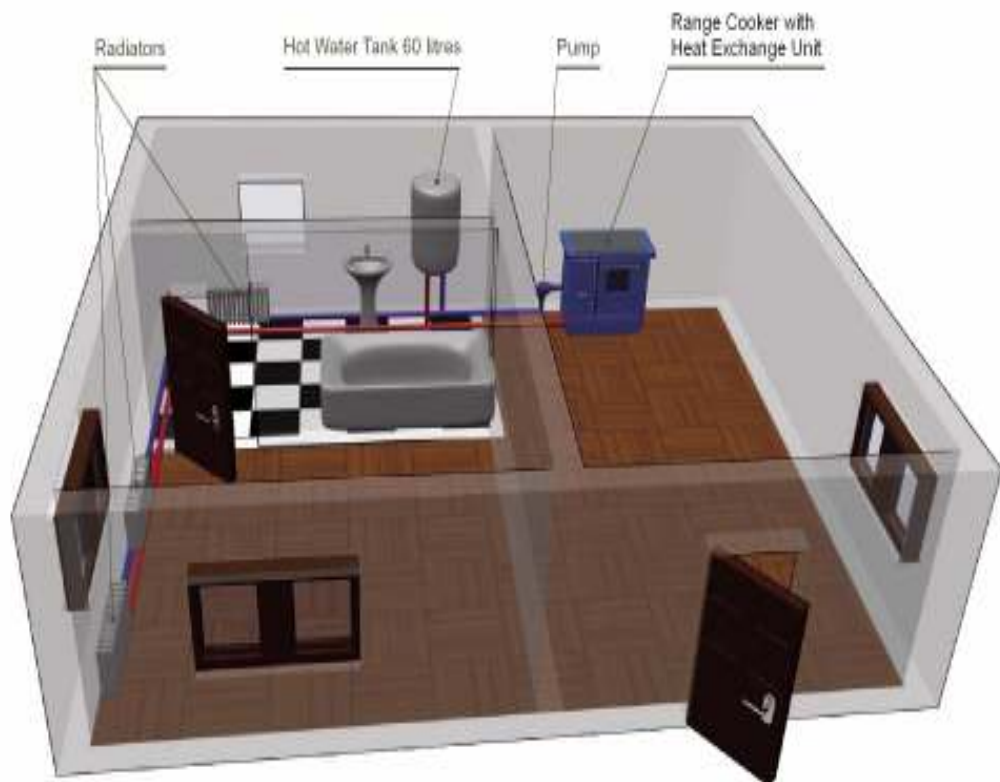



INSTRUCTIONS SCHEME FOR CONNECTION  
WITH THE EXPANSIOMATE

**IMPORTANT NOTICE**

- THE HEATING SYSTEM MUST NOT BE CONNECTED WITHOUT A SAFETY-VALVE
- THE HEATING SYSTEM MUST NOT BE CONNECTED WITHOUT A WATER PUMP
- THE HEATING SYSTEM MUST HAVE THE WATER CIRCULATION FROM 45°C

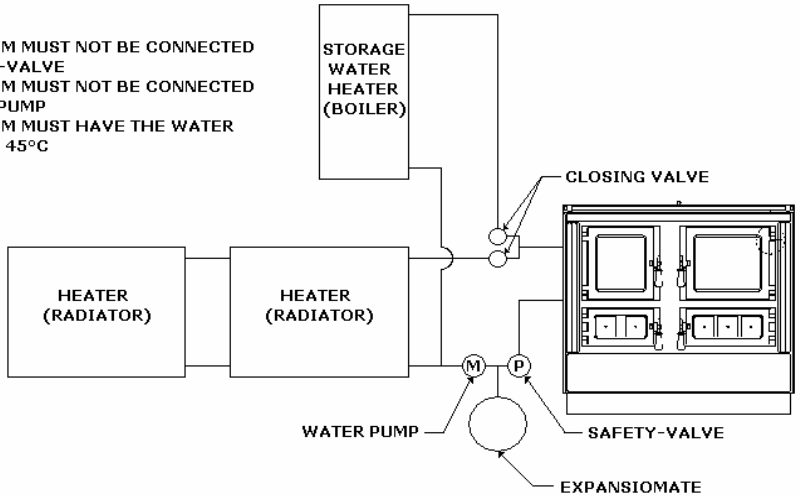

INSTRUCTIONS SCHEME FOR CONNECTION  
WITH THE OPEN EXPANSION TANK

**IMPORTANT NOTICE**

- THE HEATING SYSTEM MUST NOT BE CONNECTED WITHOUT A SAFETY-VALVE
- THE HEATING SYSTEM MUST NOT BE CONNECTED WITHOUT A WATER PUMP
- THE HEATING SYSTEM MUST HAVE THE WATER CIRCULATION FROM 45°C

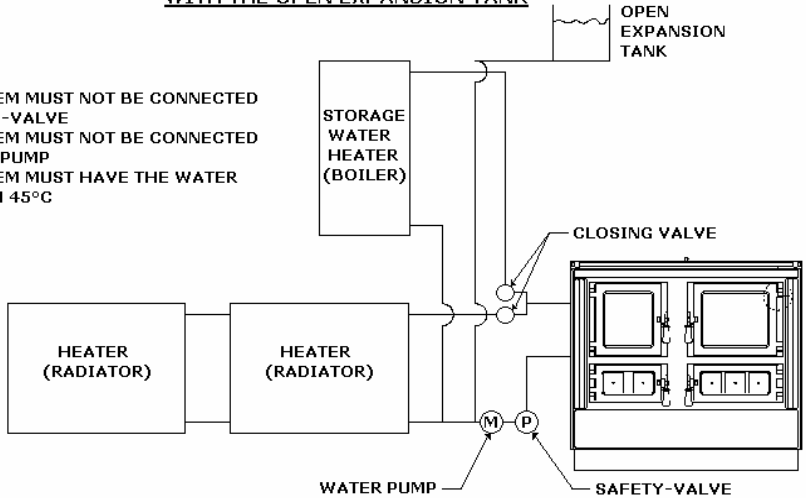

**NOTE: The valves, a pump and other safety accessories are not supplied with the cooker!**

### Spare parts sketch – part 1

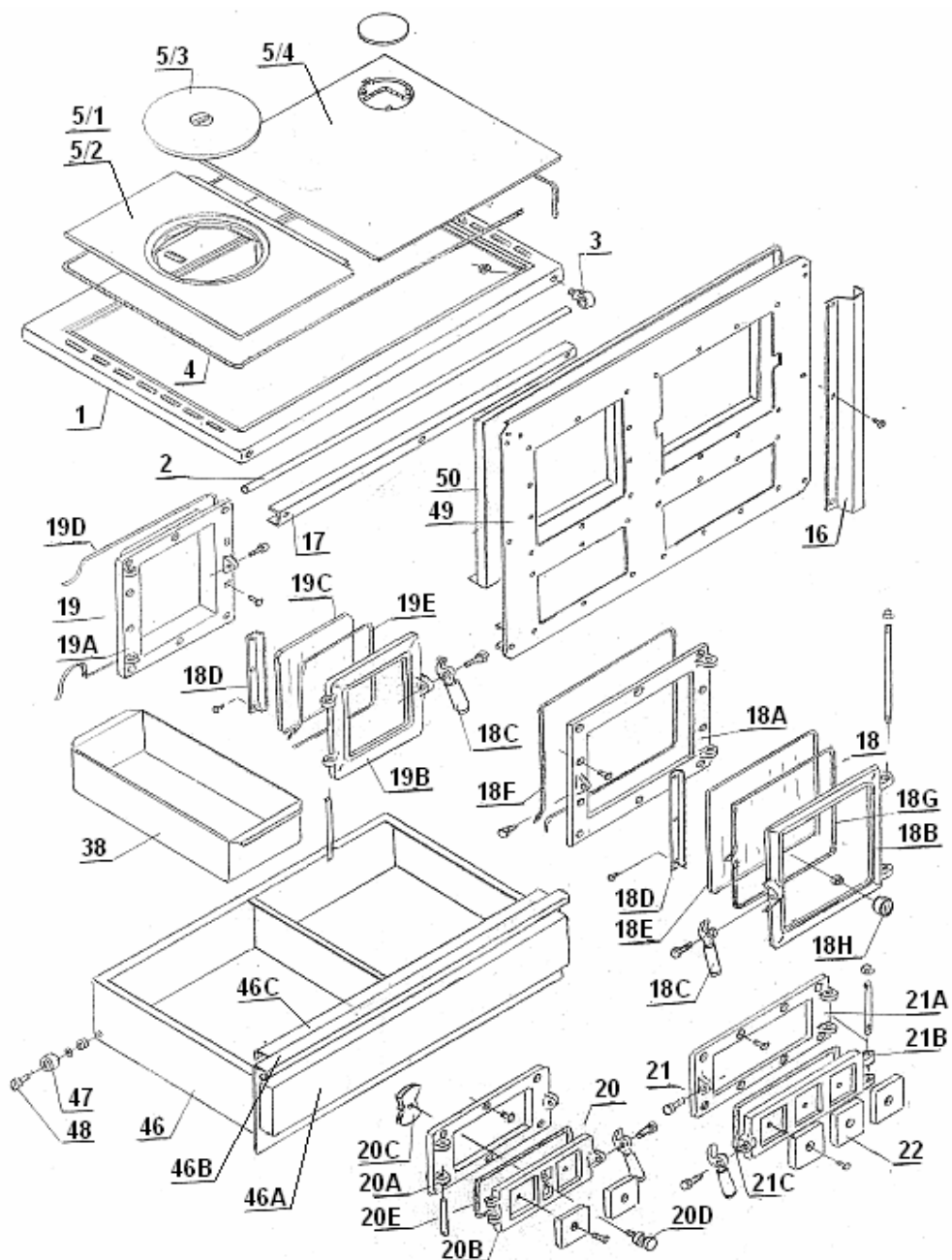

## Spare parts sketch – part 2

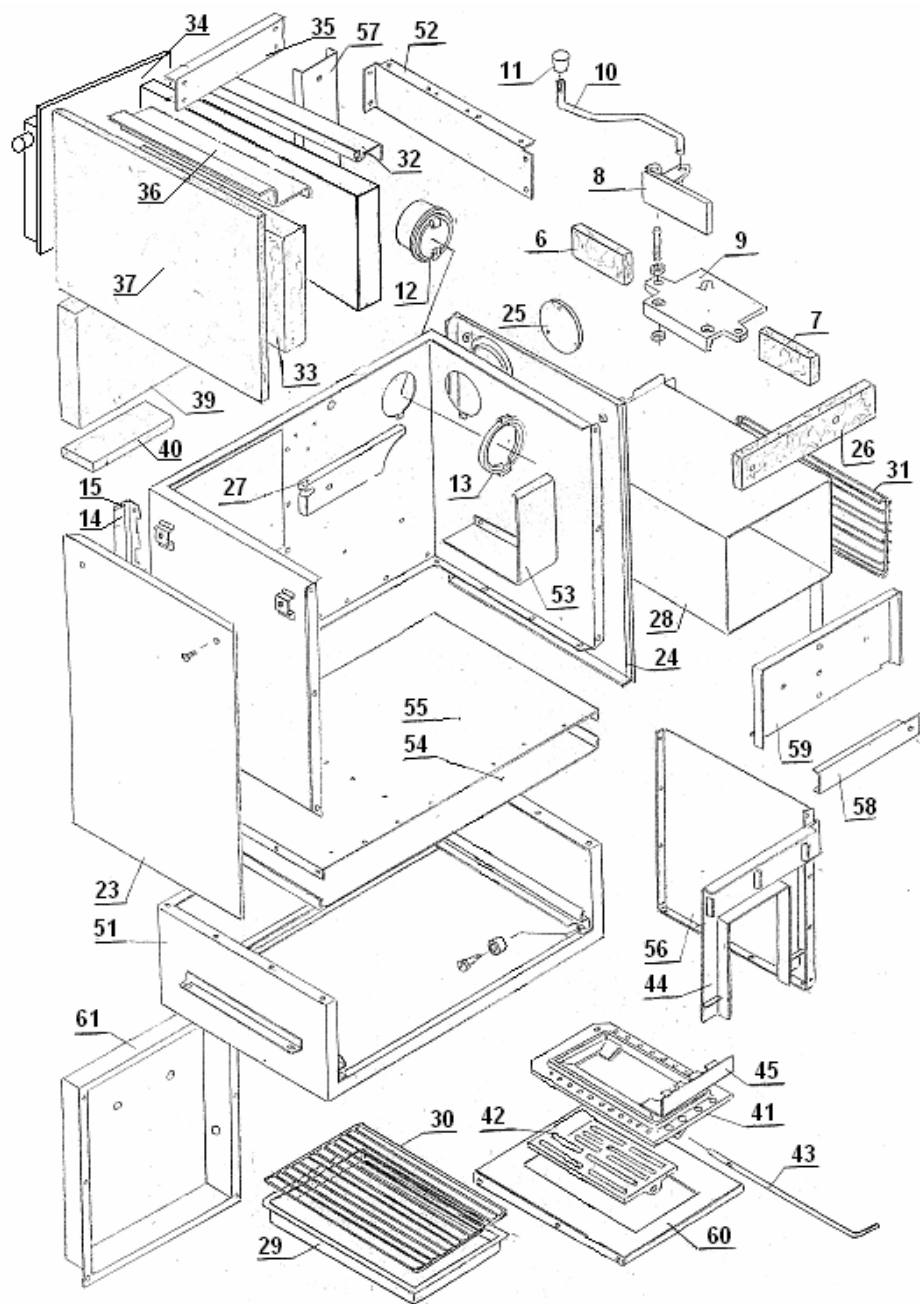

## Spare parts list

001	Hob Top set	024	Side panel with chimney outlet
002	Pipe I. set	025	Chimney outlet cover
003	Holder I. set	026	Insulation I.
004	Insulation cord Ø8,5 (2,65m)	027	Insulation II.
005/1	Hob top set (steel)	028	Oven
005/2	Hob top I. (cast iron)	029	Pan
005/3	Hob top circle lid (cast iron)	030	Baking oven grate
005/4	Hob top II. (steel)	031	Baking oven grate strut
006	Chamotte part 7 (Chamotte flap)	032	Sheet metal, set
007	Chamotte flap	033	Side chamotte panel
008	Smoke Flap	034	Heat Exchange Unit
009	Base for Oven Heating Controller (cast iron)	035	Rear top sheet
010	Oven heating control pull	036	Said top sheet
011	Top roll	037	Insulation
012	Circllet collet (cast iron)	038	Ash receiver
013	Circllet	039	Chamotte rear panel, set
014	Ribbon	040	Chamotte lower panel
015	Plug (plastic)	041	Grate bearing
016	Ribbon 2	042	Rotatable grate
017	Cover strip	043	Grate bar
018	Oven door with frame	044	Frame, set
018A	Oven door frame	045	Barrier
018B	Oven door	046	Drawer, set
018C	Closing hook, set	046A	Drawer front panel
018D	Glass holder	046B	Drawer handle
018E	Oven door glass panel	046C	Drawer ribbon
018F	Insulation cord Ø8 (1,2m)	047	Drawer caster
018G	Insulation cord Ø3 (1m)	048	Drawer caster pin
018H	Thermometer		
019	Combustion chamber door with frame		
019A	Combustion chamber frame		
019B	Combustion chamber door		
019C	Combustion chamber door glass panel		
019D	Insulation cord Ø8 (0,8m)		
019E	Insulation cord Ø3 (0,85m)		
020	Ash chamber door with frame		
020A	Ash chamber door frame		
020B	Ash chamber door		
020C	Air rose		
020D	Air rose handle		
020E	Insulation cord Ø8 (0,73m)		
021	Sweeping door with frame		
021A	Sweeping door frame		
021B	Sweeping door		
021C	Insulation cord Ø8 (0,86m)		
022	Plate		
023	Side panel		



**Producer:**



**KVS EKODIVIZE, a. s.**

plant Dvorce

Opavská 272

793 68 Dvorce u Bruntálu

**CZECH REPUBLIC**

phone: +420 554 797 111

fax: +420 554 745 500

email: [prodej.dvorce@kvs-ekodivize.cz](mailto:prodej.dvorce@kvs-ekodivize.cz)

[www.kvs-ekodivize.cz](http://www.kvs-ekodivize.cz)